

# Exploring Ratios and Shapes with

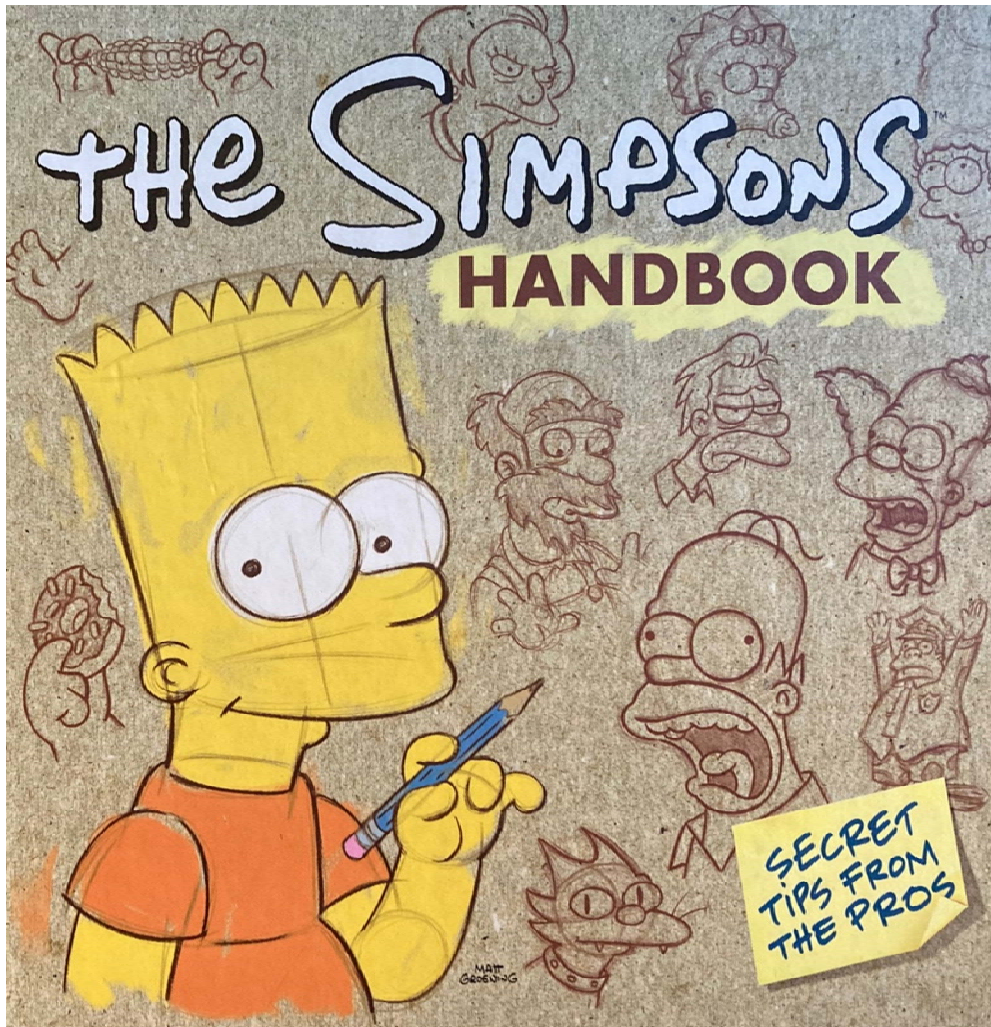

The STEAM Event  
Lewis and Clark Community  
College Math Department  
April 12, 2024

The Simpsons characters are based around common shapes and ratios (like many of our favorite cartoon characters).

The Simpsons Handbook: Secret Tips from the Pros tell us how big Bart's head is in terms of his eyeball (4-and-one-half to be exact) and how big his pupil should be within that eyeball (seven pupils fit across an eyeball).

Bart's head is a cylinder (think tin can) while Marge's head (with hair) is three circles on top of one another, with a bit of backward tilt to give her hair that natural look.

Here are some excerpts from the book to get you started drawing your favorite characters! (Ah, math ...)

Use the templates given for each character to practice.

Take care to place the first eyeball as the Tips from the Pros tells you.

Sketch in the basic head shape. Can you draw a Simpson's nose?

As with math, it's best to use a pencil with eraser.

Follow the tips given for each character for the details.

You'll amaze your friends and confound your enemies  
when you unlock the mysteries of how to draw

# BART

First, let's start at the command center,  
**BART'S HEAD**

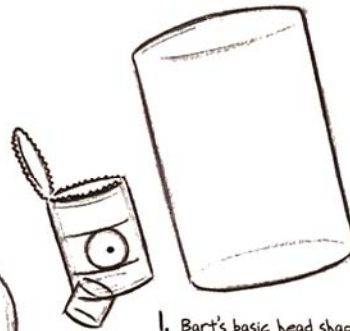
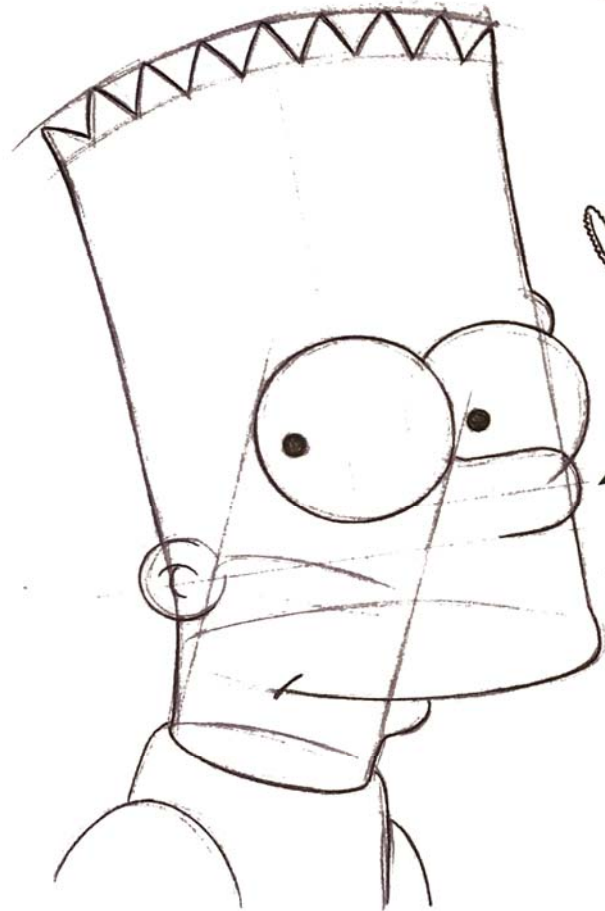

1. Bart's basic head shape is a cylinder. Think of a tin can.

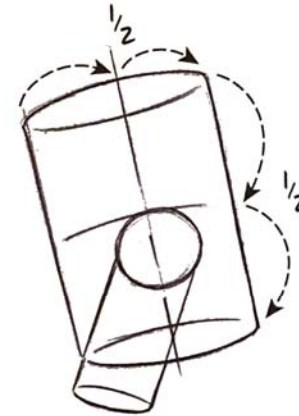

2. Center his eye between the left and right sides of his head, but just below the horizontal center line. His neck is a smaller cylinder that extends from the bottom of his head at an angle.

The top of his ear is in line with the bottom of his eye and bisects his nose.

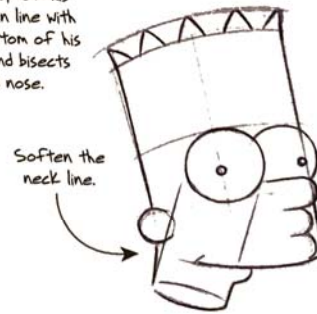

3. Begin to add hair points at evenly spaced intervals. Add his nose, ear, and mouth. Draw his second eye, tucked behind the first eye and the nose.

The distance between Bart's nose and lip is two noses.



4. Add the rest of Bart's hair points (Nine total—no more, no less!). Give him a brow bump, pupils, lower lip, and ear detail.

The top of each hair point is rounded and each point bows out slightly.



TOO PUFFY!



TOO SHARP!



A-OK-KAY!

Bart's eyeball is approximately seven pupils wide...

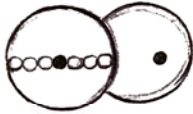

...like so!

Bart's head is roughly  $4\frac{1}{2}$  eyes high.

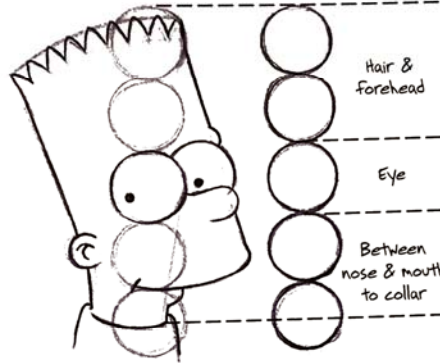

Like all the Simpsons characters, Bart's teeth are in a conical arrangement. Whether the mouth is open or closed, they should retain this shape.



The teeth follow the direction of the neck line.



As with all Simpsons family members, Bart's nose curves up just a bit.

When drawing the classic Bart grin, make sure you have at least three interior tooth lines.



Note also how the spacing decreases as the teeth curve away at the front.

There is a very slight flare on the sides of Bart's hair.



His neck inserts into the shirt collar.

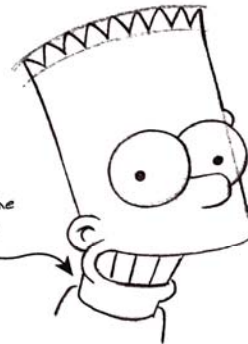

In an overachieving mood? Okay then! Let's draw

# LISA

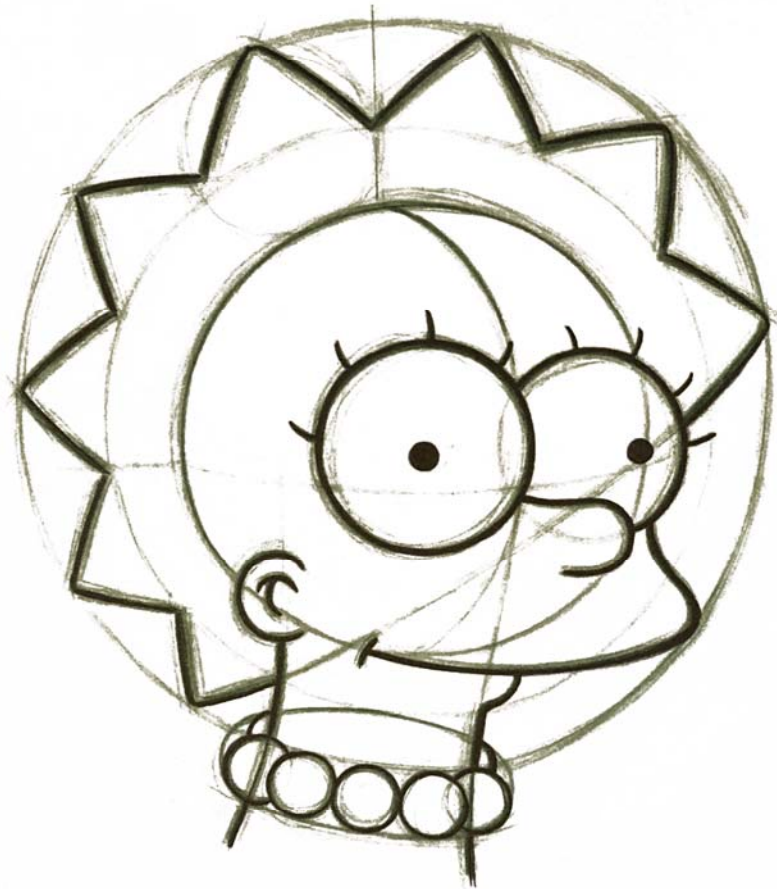

We'll get right to the point...  
...(actually eight points) with LISA'S HEAD!

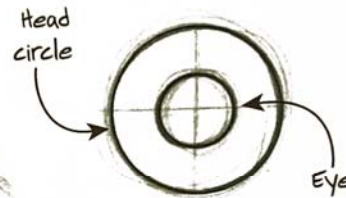

1. Start with two concentric circles. These will become Lisa's head and eye.

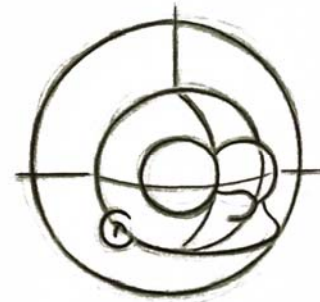

2. Add the ear, nose, and upper lip, then draw the other eye behind the forward eye and the nose. Now add the hair circle. The hair circle is not concentric with the head and eye.



3. Block in Lisa's hair, neck, and necklace. Establish horizontal and vertical center lines on the head. Divide hair points into three groups based on these center lines.



4. Tighten up and add details: pupils, eyelashes, necklace.

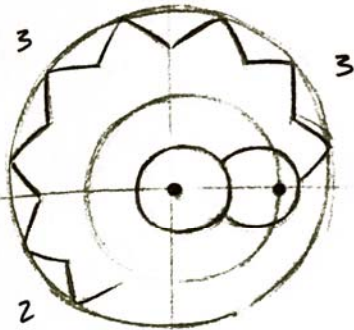

Lisa has eight points of hair, which are divided into groups of three and three (above the horizontal center) and two (below the horizon).

### Eyelashes

Not too short. Not too long.

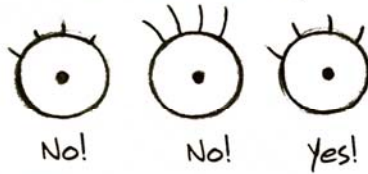

Even space between lashes.

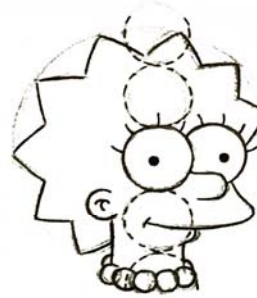
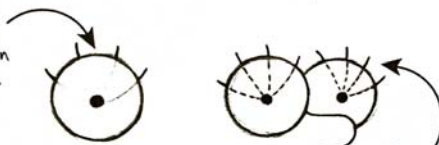

Lisa's head is  $4\frac{1}{4}$  eyeballs tall.

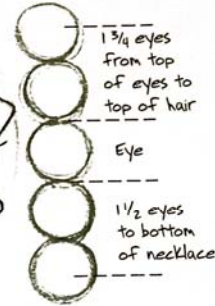

Necklace has five beads in front, with two partially showing in back on either side.

Think of Lisa's necklace as a donut around her neck. Draw through her neck to see the whole shape.

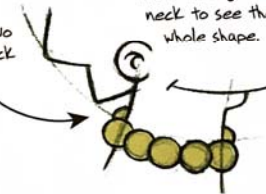

### Some notes about teeth!

The points of Lisa's hair are soft, arching triangles with lightly rounded tips.



Rounded meeting point



Lisa generally has five teeth showing when mouth is open.



When drawing a toothy grin, always slant the forward tooth in line with the neck.

As with other Simpsons family members, Lisa's teeth are in a conical arrangement. Whether the mouth is open or closed, they should retain this shape.



Teeth are never drawn in double rows like this—EVER!



Good!



Never!

Occasionally, you may want to draw Lisa from a slightly more frontal view. When doing this, leave a space between her eyes. This goes for the entire Simpsons family too.

### Some fresh notes on the eyes

These apply to ALL Simpsons characters!



No!  
Never cross the eyes!



No!

When eyes are closed or half open, don't use a complete circle for the eyelid.



Yeah!

From this slightly more frontal view, Lisa has an extra hair point showing.

Add hair point here!



And now for something completely different, let's draw

# MARGE

Sure, that towering hairdo is intimidating, but let's relax, take a deep breath, and begin with **MARGE'S HEAD**



1. Start with three equal size balls tilting back. Add an eyeball in the center of Marge's head (the bottom ball).



2. Add her nose, ear, upper lip, and cylindrical neck shape. Place her second eye behind the forward eye and nose.

Top of ear lines up with bottom of eye and bisects nose.

Upper lip extends from bottom of head ball.



3. Add facial details and hairline. Block in the necklace. Four loops of hair across forehead. Two loops of hair between ear and forehead.

Simpson family nose

Lower lip curves gently from neck into upper lip.



4. Tighten and refine your details.

Hair loops are of equal size.

Partial beads show as necklace wraps around neck.

Six main beads across front of neck.

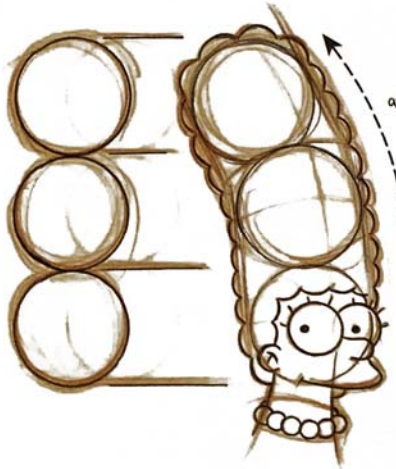

Marge's hair naturally tilts back at the top. Otherwise, it would look stiff and awkward.

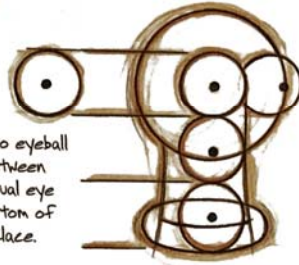

There are two eyeball lengths between Marge's actual eye and the bottom of her necklace.

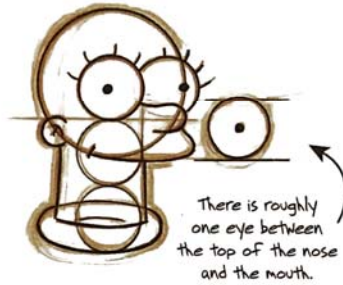

There is roughly one eye between the top of the nose and the mouth.



Line up hair loops to eliminate unruly hair and a huge bulge of hair at the base of the neck.



There are three pearls to each side of the center line.



Eyelids wrap around the eyeball.

Lashes point down when eye is closed naturally.

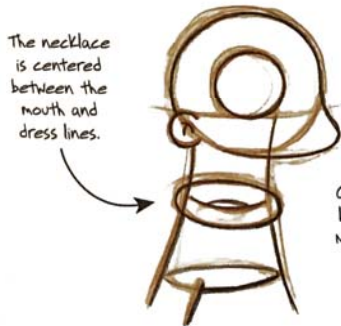

The necklace is centered between the mouth and dress lines.

Give Marge's upper lip a smooth curve. Not too pointy, not too round!

The beads touch in the center, but overlap at all other points.

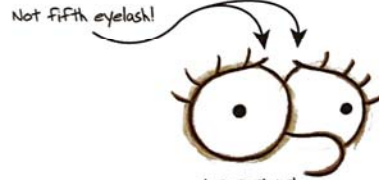

Not fifth eyelash!

IMPORTANT!

In this tricky area, when Marge is sad or upset, make sure the overlap of the eyebrow doesn't become a fifth eyelash.



For squinted eyes, lashes point up.

The expression loses energy when the lashes point down.



Now it can be revealed...  
the jealously guarded secrets of how to draw

# HOMER

Let's start with  
**Homer's Head**

and work our way down from there.

As you can see from the rough construction lines on this drawing, Homer's skull is ball-shaped, but his overall head is sort of like a giant thumb. Once you've drawn that basic shape, you can add all the other details one by one, and Homer's head will begin to take shape, as if by magic!

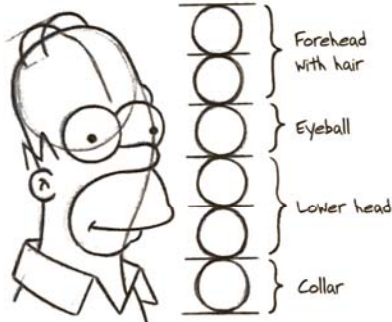

Approximately six eyeballs high!

But first, a few ground rules for drawing in the patented Matt Groening style.

**Notice!**

Big, bulgy eyeballs are a must!  
Shapes and sizes may vary,  
depending on the design  
of the individual character,  
but always keep 'em bulgy!

**Observe!**

Matt's characters  
ALWAYS have an overbite!

**Behold!**

Less is indeed more!  
Keep it simple with as few  
lines as possible!

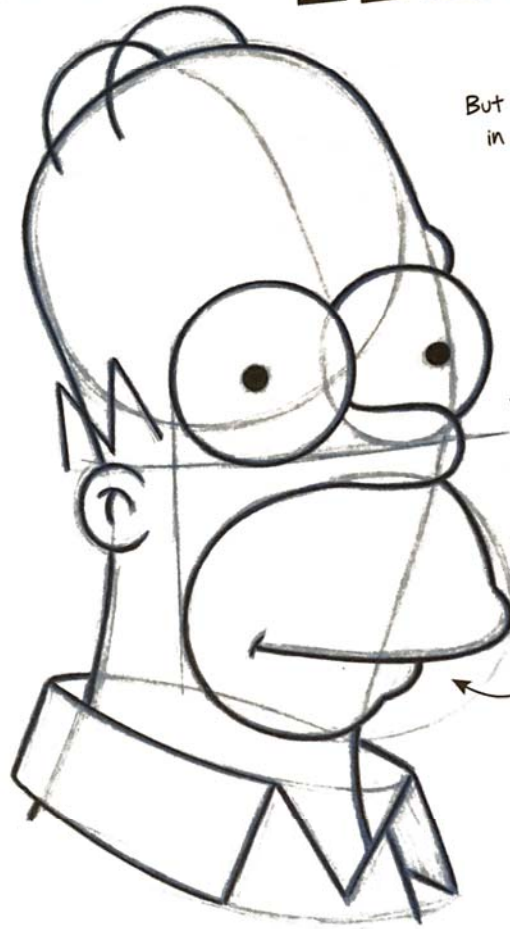

okay, step by step let's construct a 3/4 front view of HOMER'S HEAD.

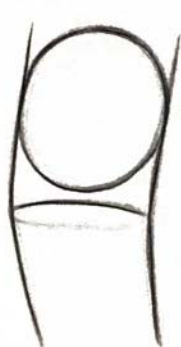

1. Start with that basic ball and thumb shape.

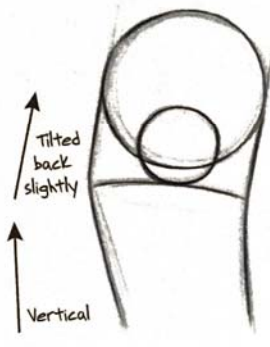

2. Establish the position of the forward eye at the bottom of the ball shape and in the center of the "thumb."



3. Add the nose. Then draw the other eye, tucked behind the nose and the forward eye.



4. Draw the mouth/beard shape. Add the ear, centered on the back of the head.



5. Give Homer pupils and add hair to the side and top of the head, then draw his shirt collar.



Homer's hair on top resembles two croquet hoops, one in front of the other!

His hair on the side resembles an "M" for Matt! Note how the "M" is positioned on the head with the bottom point just to the inside of the head.



Ears are round with a curvy T-shaped inner ear detail. They should have the same thickness all the way around.



To determine the size of the pupils, you should be able to fit seven of them end to end from one side of the eyeball to the other.

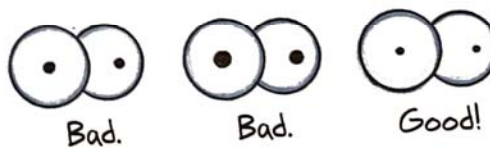
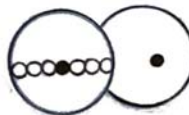

To draw the mouth/beard shape, think of it like a coconut divided in half, except that the bottom half is about 1/3 smaller than the top half.

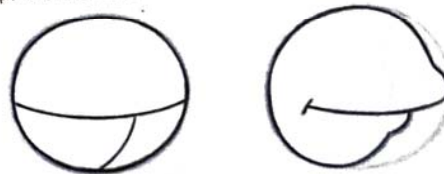

Now that you have Lisa down pat, it'll be a snap to draw

# MAGGIE

As you would expect by now, we'll start with  
MAGGIE'S HEAD



1. Start with a donut.  
(No sprinkles, please!)

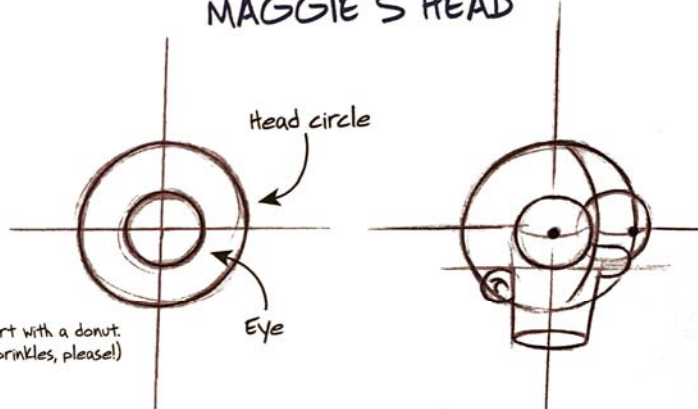

2. Add the ear and nose,  
then draw the other eye  
behind the forward eye and  
the nose. Add the cylindrical  
neck shape.



3. Block in her pacifier and add  
the hair circle. The hair circle is not  
concentric with the head and eye. Block  
in Maggie's hair. You can also draw an inside  
circle to define how deep each hair point  
should go. Maggie has 8 points of hair,  
but they are not in the same arrangement  
as Lisa's. See if you can spot  
the difference!

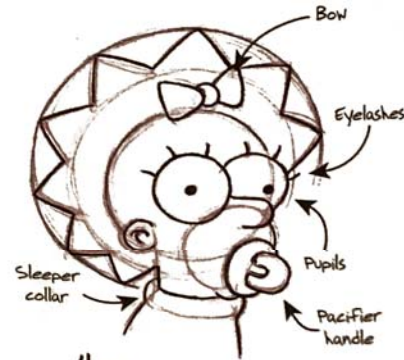

4. Add details and tighten.

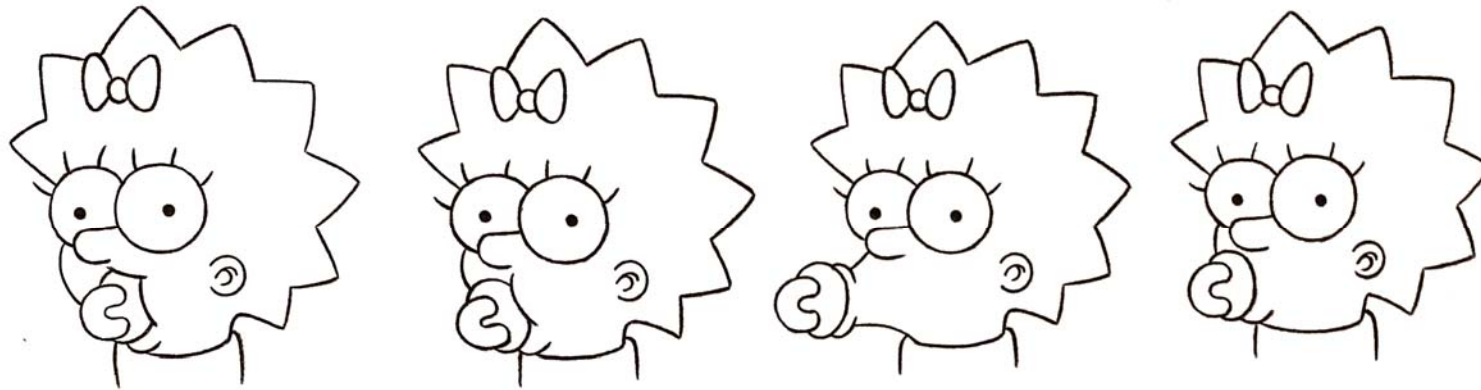

## MAGGIE'S PACIFIER SUCKING CYCLE

Maggie's eyelashes are like Lisa's, except that she only has three of them! They are of equal length and are equally spaced.

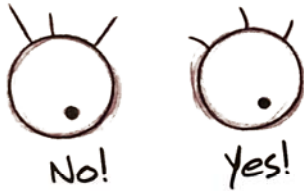

Maggie's head is 4 1/2 eyeballs high.

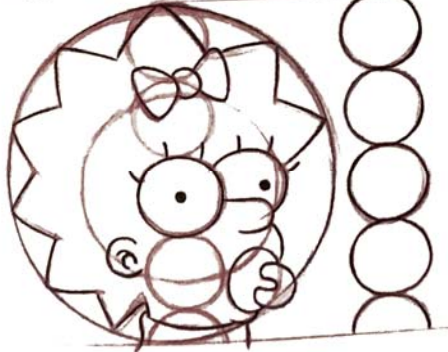

The points of Maggie's hair are soft, arching triangles with lightly rounded tips.

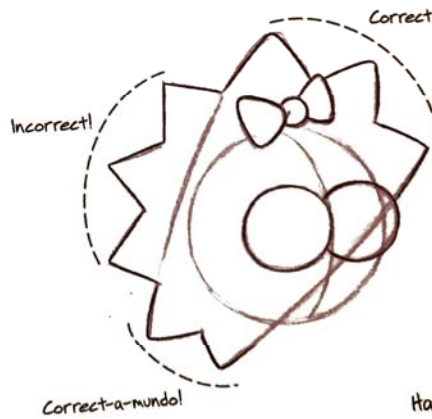

Hair points are arranged in a 3-3-2 setup on a tilted axis.

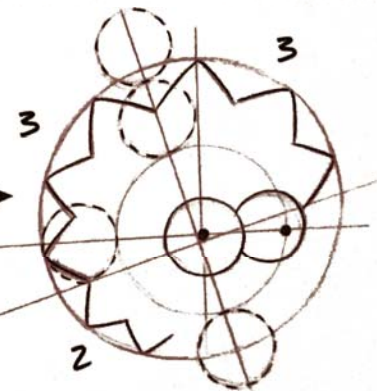

BART

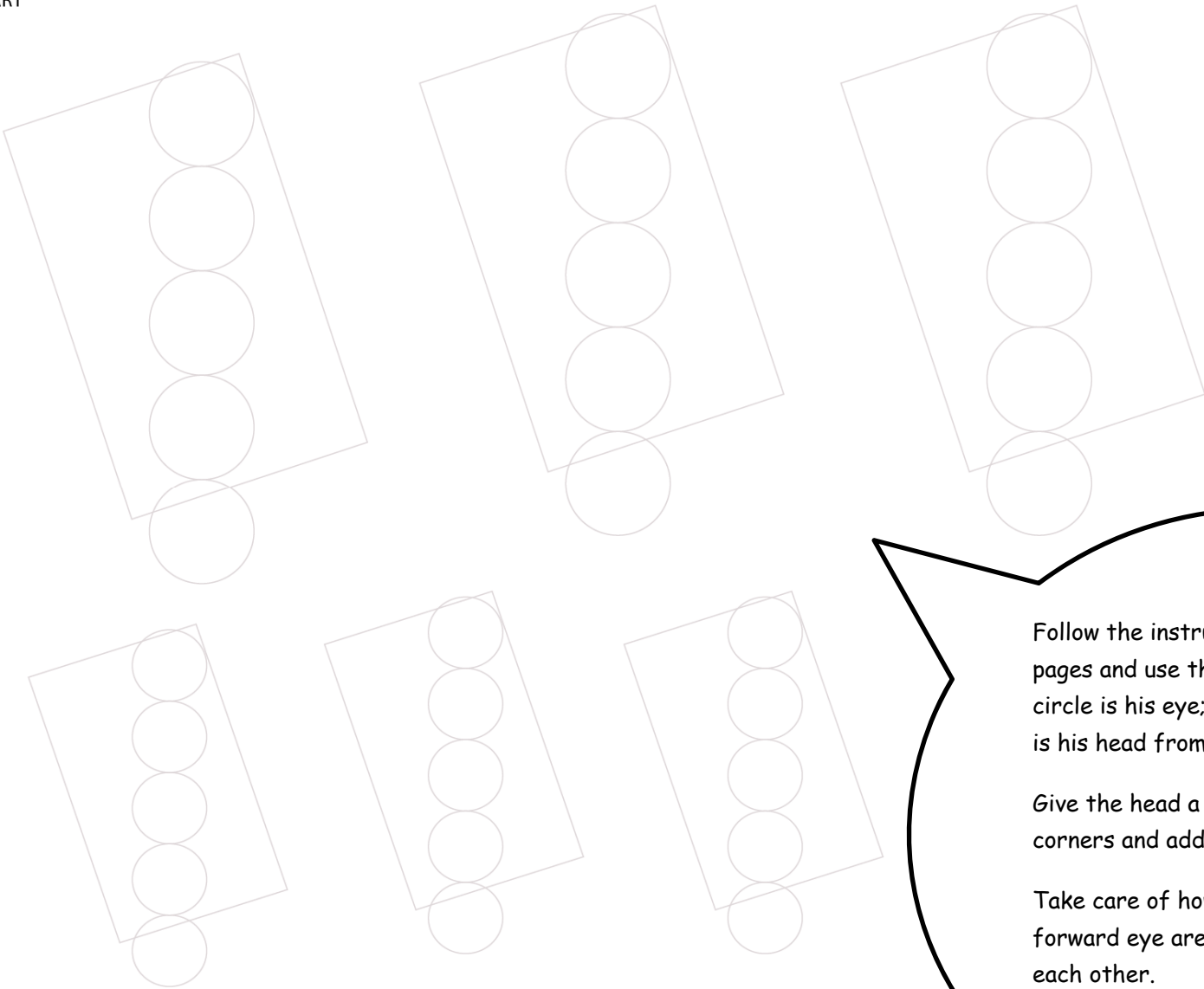

Follow the instructions on the previous pages and use these templates. The middle circle is his eye; start there. The rectangle is his head from top to upper lip.

Give the head a little flair at the top corners and add some hair.

Take care of how the ear, nose, and forward eye are arranged in relation to each other.

Experiment with where he is looking!

LISA

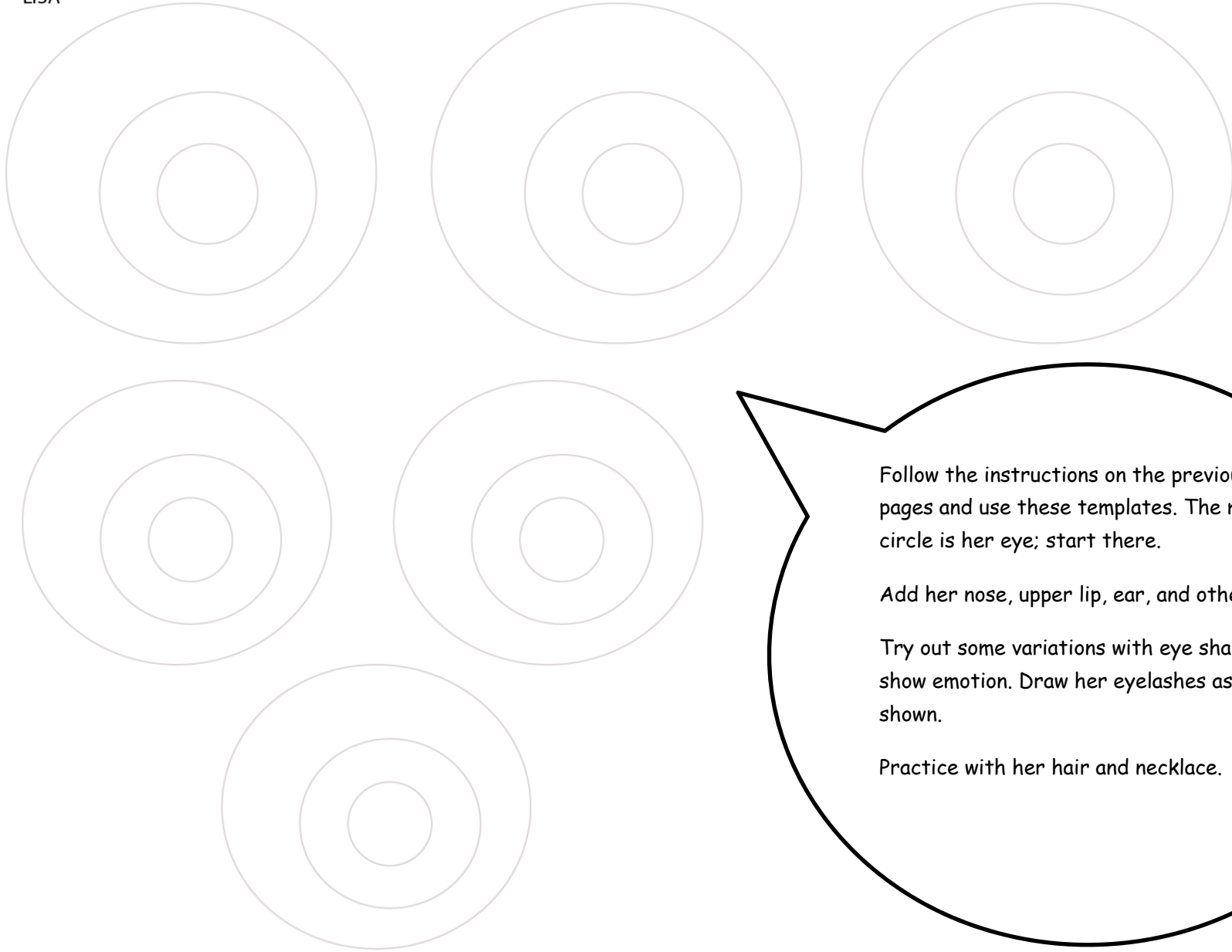

Follow the instructions on the previous pages and use these templates. The middle circle is her eye; start there.

Add her nose, upper lip, ear, and other eye.

Try out some variations with eye shapes to show emotion. Draw her eyelashes as shown.

Practice with her hair and necklace.

MARGE

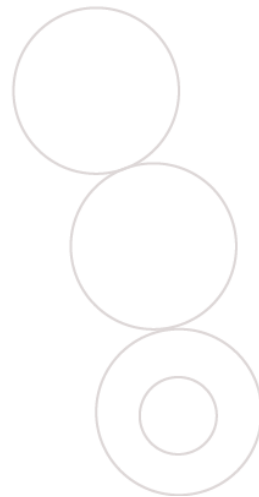
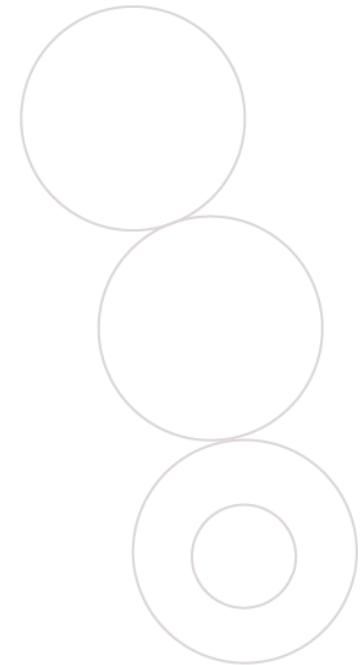
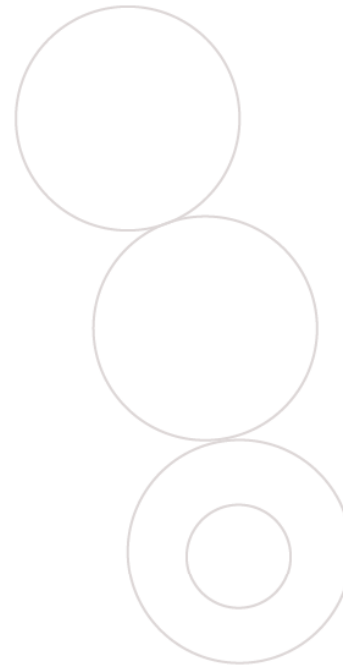
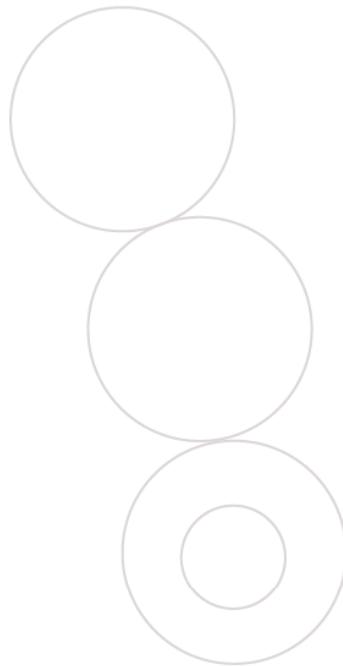
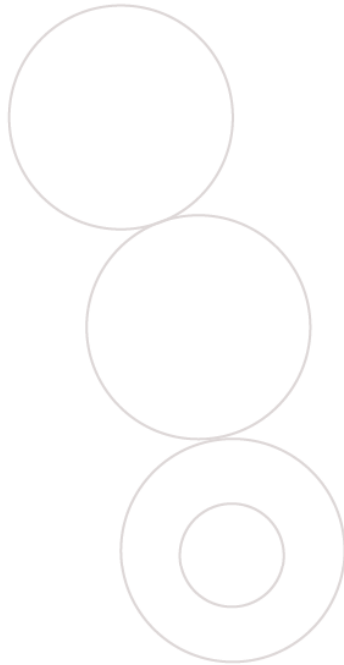

Follow the instructions on the previous pages and use these templates. Three circles, tilted back, make up her head/hair. The bottom, inside circle is her eye; start there.

Give her some hair on the forehead, not too much nor too little. Block details in at first and then refine.

Play with her eyes and lips to display emotion. Can you make Marge scowl?

## HOMER

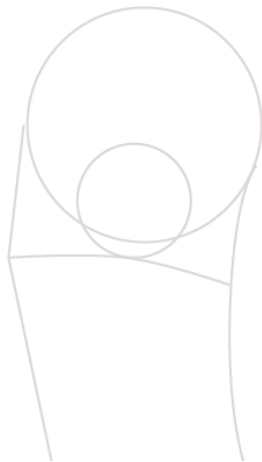
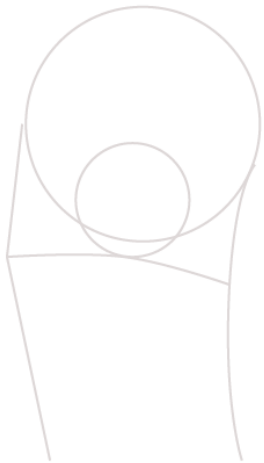
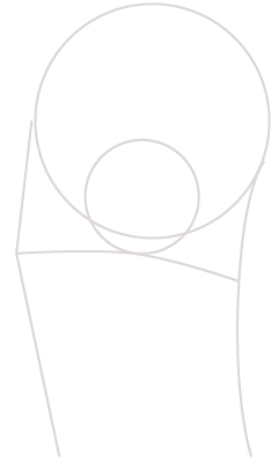
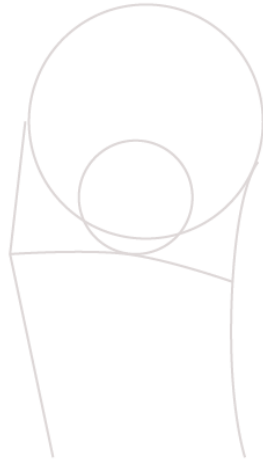
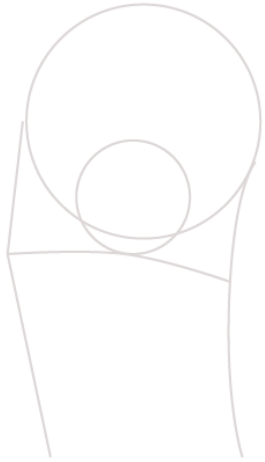

Follow the instructions on the previous pages and use these templates. The overall head shape is "thumb". That middle circle is his eye; start there.

His spacing is described as "1½ eyes from the top of eye to top of head" and "2½ noses between bottom of nose and mouth".

Place the hair, beard line, and other details according to the instructions given. Does your Homer have an ear yet? Try to draw his shirt.



MAGGIE



Follow the instructions on the previous pages and use these templates. Again, the inside-most circle is her eye; start there.

Add an ear and her nose, followed by the other eye. Give her a cylinder for her neck.

Block in the pacifier and give her hair. Her hair goes in between the two outer circles. Refine the details with the instructions given.

Experiment with her sucking cycle.